



Date Issued: September 2017	Page No.: 1	Document No.: SOP-Biosafety-03
Revision: 2.0	Subject: Biological Safety Cabinets	

1. Introduction and Scope

When properly maintained and used in conjunction with good laboratory techniques, Biological Safety Cabinets (BSCs) provide effective primary containment for work with human and animal pathogens.

The type of BSC determines whether it provides only protection for the operator, or protection for both the operator and the material in use i.e. whether or not it provides an aseptic environment. Product and operator protection is provided by a curtain of HEPA filtered air that is directed in a laminar flow pattern down from the top of the BSC and into grills at the back and front of the BSC. Contaminated air that is drawn in the front of the BSC and air contaminated within the BSC is HEPA filtered before being exhausted from the cabinet or recirculated onto the work surface.

Note that there are also “laminar flow cabinets/hoods/clean air hoods” that provide only product protection, but no operator protection. These are not BSCs (although they may look somewhat similar), so it is important to know the difference and be sure that you are using a BSC when operator protection is needed. Most often these have air blowing towards the operator, which is not the case with a BSC.

Also note that a fume hood is not the same as a BSC. More details about this are provided in this SOP.

In containment level 2 facilities, BSCs are used for procedures with the potential to produce infectious aerosols and for high concentrations or large volumes of infectious material.

- Most operations with level 2 material should be performed in a BSC, but some low risk procedures may be performed on the open bench if assessed as part of a risk assessment that is approved by the Biohazard Committee.
- *All manipulations* of biohazardous agents that require level 2 containment with level 3 operational practices (commonly called 2+) must be performed in a BSC.

This SOP outlines the safety policies and work practices to provide optimum contamination control and safety when working in a BSC.

2. Applicable Legislation, Standards, Guidelines



Date Issued: September 2017	Page No.: 2	Document No.: SOP-Biosafety-03
Revision: 2.0	Subject: Biological Safety Cabinets	

Canadian Biosafety Standards, 2nd Edition, 2015 (CBS; Public Health Agency of Canada (PHAC) and Canadian Food Inspection Agency (CFIA))

Canadian Biosafety Handbook, 1st Edition, 2016 (CBH; PHAC and CFIA)

National Sanitation Foundation (NSF) Standard No. 49-2010 for the design, manufacture and testing of BSCs (NSF-49)

3. Definitions

Clean Air Benches

Clean air benches do NOT protect the worker and are NOT BSCs. Clean air benches have HEPA filtered laminar airflow *towards the worker*. They provide a flow of clean air over the product and protect it from contaminants in the environment. A clean air bench provides product protection only. The worker is directly exposed to aerosols and particulates from the work. Clean air benches are not to be used for work with biohazard risk group 2 material, hazardous volatile chemicals (or particulates), or radioisotopes.

HEPA filter

HEPA filters can remove at least 99.97% of airborne particles 0.3 µm in diameter. Particles of this size are the most difficult to filter and are thus considered the *most penetrating particle size* (MPPS). *Particles that are larger or smaller than 0.3 µm are filtered with even higher efficiency.* However, **HEPA filters do not prevent gases from passing through.**

HEPA filters are composed of a mat of randomly arranged fibres. Particles are trapped (stick to a fibre) by one of the following three mechanisms:

- 1) *Interception*, where particles following a line of flow in the air stream come within one radius of a fibre and adhere to it.
- 2) *Impaction*, where larger particles are unable to avoid fibres by following the curving contours of the air stream and are forced to embed in one of them directly; this effect increases with diminishing fibre separation and higher air flow velocity.
- 3) *Diffusion*, an enhancing mechanism is a result of the collision with gas molecules by the smallest particles, especially those below 0.1 µm in diameter, which are thereby impeded and delayed in their path through the filter; this behaviour raises the probability that a particle will be stopped by either of the two mechanisms above; it becomes dominant at lower air flow velocities.



Date Issued: September 2017	Page No.: 3	Document No.: SOP-Biosafety-03
Revision: 2.0	Subject: Biological Safety Cabinets	

Diffusion predominates below the 0.1 μm diameter particle size. Impaction and interception predominate above 0.4 μm . In between, near the 0.3 μm MPPS, diffusion and interception predominate.

Biological Safety Cabinet

The unique directional airflow in a BSC consists of:

- (1) HEPA-filtered air that passes over the work surface to provide a clean working environment;
- (2) an "air curtain" at the main opening that prevents the mixing of potentially contaminated air from the laboratory with the HEPA-filtered air in the BSC;
- (3) continuous negative pressure in the BSC that is created by a continual draw of air into the BSC. This prevents the air inside from escaping into the laboratory;
- (4) the air that is exhausted out of the cabinet into the laboratory is HEPA-filtered to **prevent release of particulate contaminants.**

NSF certified biosafety cabinetry should be used for level 2 containment.

- NSF/ANSI Standard 49, includes basic requirements for design, construction and performance to provide personnel, product and environmental protection; reliable operation; durability; cleanability; noise level and illumination control; vibration control; and electrical safety. In addition, the standard includes detailed test procedures and informational annexes, including recommendations for installation, field certification tests and decontamination procedures.
- Where a custom enclosure or the design of a BSC or similar enclosure (e.g. Biobubble) does not permit certification in accordance with NSF/ANSI 49, it is to be verified to meet the manufacturer's specifications, with minimum parameter values specified in Matrix 5.1 of the CBS

There are three classes of BSC and selection of the proper class requires careful evaluation of the activities to be carried out:

Class I - have un-recirculated airflow away from the operator that is discharged to the atmosphere after filtration through a HEPA filter. They provide good operator protection but no product protection.

Class II types A1, A2, B1, and B2 - are designed for personnel, product and environmental protection. The main difference between the types are the ratio of air



Date Issued: September 2017	Page No.: 4	Document No.: SOP-Biosafety-03
Revision: 2.0	Subject: Biological Safety Cabinets	

exhausted from the BSC to that which is recirculated within the BSC, and the type of exhaust system present. Type A cabinets usually exhaust filtered cabinet air into the room, but are sometimes ducted out of the building by means of a "thimble connection".

- Type A1 cabinets are never hard-ducted (i.e. never exhausted by a hard duct to the outside of the building) and are not suitable for work with volatile toxic chemicals or volatile radionuclides because 70% of the air is recirculated which could cause a dangerous buildup of the toxic materials inside the BSC, or inside the containment zone.
- Type A2 cabinets, appear similar to type A1 cabinets; however, they have a greater inflow velocity and always have negatively pressured contaminated plenums or positively pressured contaminated ducts/plenums surrounded by negatively pressured ducts/plenums. This design feature ensures that the potential leaks in the positively pressured ducts or plenums are drawn inward rather than out into the containment zone. This type of BSC is suitable for work with minute amounts of volatile toxic chemicals and radionuclides, if ducted out of the building with a thimble connection.
- Type B cabinets are hard-ducted through a dedicated duct exhausted to the atmosphere after passage through a HEPA filter.
 - Type B1 is suitable for work with low levels of volatile toxic chemicals and trace amounts of radionuclides, as long as the work is performed towards the back of the cabinet where air is discharged directly to the outside atmosphere.
 - Type B2 is suitable for work with volatile toxic chemicals and radionuclides because they are hard-ducted and the airflow within them is designed so that air is never recirculated within the BSC or within the containment zone.
 - Reversal of airflow from the face of a BSC, also known as a **puff-back**, can occur in Class II type B2 BSCs, for example upon failure of the HVAC system, power, or the exhaust fan serving the BSC. Every effort is to be made to address puff-backs mechanically (CBS Matrix 3.7). Consideration should also be given to the amount of air required to operate this type of cabinet as it may lead to additional adjustments to balance the airflow in the containment zone.
- Type C1 is a new type of BSC that can be used in a recirculating Type A-mode for standard microbiological work, or can be connected to an exhaust system to function in Type-B mode for handling hazardous chemical vapors or



Date Issued: September 2017	Page No.: 5	Document No.: SOP-Biosafety-03
Revision: 2.0	Subject: Biological Safety Cabinets	

radionuclides. There are several advantages to this design over a traditional Type B BSC, so they should be considered if direct exhaust is required.

- A table and figures detailing the features of the most common BSCs at Queen's are provided in the Appendix.

Class III – are totally enclosed and gas-tight with HEPA filtered supply and exhaust air. Work is performed with attached long-sleeved gloves. They are designed for work with level 4 pathogens. None are in use at Queen's University.

4. Responsibilities

Responsibilities of Department Heads

- Ensure that supervisors, employees and students are notified of their responsibilities for working with BSCs.
- Ensure that all employees and students have received instruction in the proper use of a BSC.
- Ensure that the components of this SOP and the applicable legislation are implemented in all facilities under the Head's authority.

Responsibilities of Supervisors

- Ensure that the correct type of BSC is used for the intended work.
- Contact EH&S to consult regarding purchase and placement in the laboratory.
- Ensure that BSC users receive safety training regarding best laboratory work practices and this SOP prior to commencing work with BSCs.
- Ensure that a BSC is decontaminated prior to being moved.
- Ensure that a BSC is tested and certified to NSF Standard 49 annually.
- Ensure that a BSC is tested and recertified after being moved. This is necessary because the HEPA filter can shift out of alignment or seals crack, and not function properly if the BSC is moved even a short distance.
- Ensure that no work is performed in a malfunctioning BSC.
- Receive report from EH&S regarding results of BSC testing.
- Coordinate maintenance, repair and new BSC equipment needs with EH&S.

Responsibilities of Users (Staff/Students)

- Understand how a BSC works.
- Ensure that the correct type of BSC is used for the intended work.



Date Issued: September 2017	Page No.: 6	Document No.: SOP-Biosafety-03
Revision: 2.0	Subject: Biological Safety Cabinets	

- Follow the procedures for BSC use described in this SOP.
- Notify the Laboratory Supervisor/Principal Investigator immediately in the event of BSC malfunction.
- Notify the Biosafety Officer if a BSC malfunction may have caused an exposure.

5. User Guidelines

5.1. Purpose and Use of the BSC

- Biological Safety Cabinets (BSCs) are the primary means of containment for working safely with biohazardous agents. BSCs are designed to reduce the risk of infection by isolating the activities in the BSC from the laboratory environment.
- BSCs provide personnel protection and environmental protection by using a combination of directional airflow and a High Efficiency Particulate Air (HEPA) filter. Bacteria, spores and viruses are removed from the HEPA-filtered air.
 - There are different types of BSCs, some of which provide only personnel and environmental protection, and others that also provide product protection. This SOP applies primarily to the latter, Class II BSCs. Note that type AI and A2 BSCs are usually installed so that the air is re-circulated back into the laboratory.
 - It is important to know what type of BSC you are using. **If work with biohazardous material also involves hazardous vapours or gases then you must use a BSC that is vented outside the building.** A fume hood does not provide the same protection as a vented BSC.
 - See the description in the definition section and also the appendix to this SOP for more information about the types of BSCs.

5.2. Mechanical Operation of a Biological Safety Cabinet

- **Operation Panel and Main Features:** The functions of a BSC are controlled through a panel located on the front of the cabinet above or beside the sash (window). Switches on the panel control the lighting, the blower/fan system, the electrical outlets, and the alarm system bypass.



Date Issued: September 2017	Page No.: 7	Document No.: SOP-Biosafety-03
Revision: 2.0	Subject: Biological Safety Cabinets	

- Magnehelic Gauge:** Routinely monitor the pressure on the magnehelic gauge so that you will know what it should be for your cabinet since the normal reading differs from one cabinet to another. The magnehelic gauge provides a "gross" or approximate indication of HEPA filter loading, i.e., the volume of particulate matter the filter has accumulated as the cabinet operates. It provides one indication of how rapidly the filter's capacity is being diminished. This is measured by reading either motor blower suction or pressure.
- Blower:** The blower motor should be turned on at least 5 minutes prior to using the BSC. To maintain the proper airflow pattern, the sash (window) should only be opened to the height marked on the front panel (usually a maximum of 10 inches). Although the BSC may be turned off after decontamination as described under "Upon completion of work" (page 6), many users choose to leave the BSC running continuously to maintain a clean environment at all times. In addition, if a BSC is used many times during a day, it should be left running until all work is complete because frequent turning on and off of the BSC decreases the life expectancy of the motor.
- Alarm:** There should be an alarm that will sound if the air circulation in the cabinet has been compromised (usually because the sash or window has been raised too far, but also for other reasons such as a blocked HEPA filter). A BSC must not be used when an alarm sounds or a warning light is on. An alarm must never be disengaged as it indicates improper airflow which affects the cabinet's performance and may endanger the researcher or the experiment.

 - On older BSCs that do not have alarms, it is particularly important to routinely check the magnehelic gauge to ensure that the air flow pressure remains constant.
- Lighting:** There are two types of lighting inside the BSC: fluorescent and Ultraviolet (UV). The fluorescent light should normally be ON while work is being done within the cabinet. Although the direct exposure to UV light (approximately 260 nm wavelength) can reduce the number of pathogenic microorganisms on exposed surfaces and in air, **the routine use of UV lamps to decontaminate a BSC is not recommended for the following reasons:**

 - UV light has poor penetrating power. UV irradiation is ineffective if a **microorganism** is protected by dust, dirt, or organic matter. A liquid



Date Issued: September 2017	Page No.: 8	Document No.: SOP-Biosafety-03
Revision: 2.0	Subject: Biological Safety Cabinets	

chemical disinfectant should be the primary method of cleaning and disinfecting the interior of a BSC.

- UV irradiation does not penetrate into cracks or through the grilles of a BSC.
- UV irradiation can cause deterioration of various materials, including certain plastics and tubing
- the accumulation of dust, dirt, grease or clumps of microorganisms reduce its germicidal effects;
- exposure to UV light is hazardous: it may result in severe eye damage and burns to the skin.

Nevertheless, UV lights may be **useful in certain situations, if properly maintained, such as when using spore-forming bacteria since bacterial spores are resistant to chemical disinfection.**

- UV irradiation of the work area should only be used as a secondary method of disinfection in the cabinet. Never rely on UV irradiation alone to disinfect a contaminated work area.
- The UV lamp should be routinely tested with a UV meter to verify that the proper intensity (i.e., 40 $\mu\text{W}/\text{cm}^2$) is being delivered at the appropriate wavelength (i.e., 254 nm) in the centre of the work area.
- UV lamps **must** be turned off whenever the laboratory is occupied unless the sash can be lowered so that it is completely closed.
- **Outlets:** Electrical devices can be used inside the BSC by using the plugs provided.

5.3. Procedures for Use of the Biological Safety Cabinet

Planning: Thoroughly understand the procedures to be performed. Thoroughly understand the functions and limitations of the BSC that you are using. Identify/collect and place all of the necessary equipment in the BSC prior to beginning work.

- **Only one person should work in a BSC at one time (even in 6 foot long BSCs).** Two people will disrupt the airflow, creating turbulence that could result in biohazardous aerosols coming out of the cabinet, or cause cross-contamination of work in the cabinet. i.e. it can be hazardous for you and/or your science.
- **Large BSCs are appropriate for experiments that need lots of space, not for two people to work at one time.**



Date Issued: September 2017	Page No.: 9	Document No.: SOP-Biosafety-03
Revision: 2.0	Subject: Biological Safety Cabinets	

Start-up:

- Turn **OFF** the UV lamp (if it is on) and turn **ON** the fluorescent light.
- Check that the sash is at the appropriate height. Adjust stool height so that the user's underarms are level with the bottom of the sash.
- Turn **ON** the blower (if it is off; many labs leave the blower running all the time) and allow it to run for at least 5 minutes before starting work in the cabinet.
- If present, test the airflow alarm and ensure it is switched to the "on" position.
- Routinely monitor the pressure on the pressure (magnehelic) gauge so that you will know what it should be for your cabinet since the normal reading differs from one cabinet to another. If the differential pressure drops by more than 0.2 then do not use the cabinet and call for service.

Disinfect the interior surfaces with a disinfectant appropriate for the biohazardous agents used in the laboratory (e.g. 70% Ethanol (EtOH), Virox, an H₂O₂ disinfectant). Note that bleach can corrode the stainless steel and make the BSC difficult to decontaminate so it should not be used for routine decontamination. If bleach or other corrosive disinfectant is required (e.g. for spill clean-up) then be sure to thoroughly rinse the surface.

- Assemble all materials required for manipulation and load into the BSC.
 - Care should be taken not to overcrowd or block the front or rear grilles to prevent the appropriate airflow patterns from being compromised.
 - **Disinfectant effective against the agents in use should be placed inside the BSC** so that you do not have to reach out with contaminated gloves to get it.
 - Place **aerosol generating equipment** (e.g., vortex mixer, sonicator) towards the back of the BSC, without blocking the rear grille.
 - When there is significant **potential for splatter or splashes** to occur during manipulations of infectious material or toxins, the work area should be lined with a plastic-backed absorbent pad.



Date Issued: September 2017	Page No.: 10	Document No.: SOP-Biosafety-03
Revision: 2.0	Subject: Biological Safety Cabinets	

- After loading material in the BSC, allow sufficient time for the air to purge and the airflow to stabilize before initiating work. This will be specified in the manufacturer's instructions, and is generally 3-5 minutes.

Working in the BSC

- Wear protective gloves that cover the cuffs of lab coat sleeves to prevent contaminated air from entering the sleeve. Lab coats (or closed front gowns) with fitted cuffs rather than loose sleeves are recommended.
- Perform operations as far to the rear of the work area as reasonable. Ensure that elbows and arms do not rest on the grille or work surface.
- Movement of arms into and out of the cabinet can disrupt airflow, which can allow contaminants to enter or escape the BSC. Whenever possible, place all materials needed for a procedure inside the cabinet before starting. Move arms slowly and move straight out of the cabinet perpendicular to the front opening; do not sweep arms across the front of the cabinet. Do not walk quickly in front of a cabinet when someone else is working.
- Place supplies, equipment and papers well back from the front of the cabinet, positioned so that air intake or exhaust grills are not obstructed.
 - Never put anything on the grill at the front opening of the cabinet.
 - Do not block the air openings/grill at the back of the cabinet.
- Segregate non-contaminated ("clean") items from contaminated ("dirty") items. Work should always flow from "clean" to "dirty" areas
- Material should be discarded in a **waste** container **located towards the rear of the cabinet** workspace. **Do not discard materials in containers outside of the cabinet.**
- Before using vacuum aspiration, verify that there is fresh bleach in the collection flask (final concentration when the flask will be full of at least 0.5% hypochlorite in the collection flask (i.e. 8.3% to 10% final dilution of stock bleach, depending on the concentration of stock bleach - 5% to 6% hypochlorite).



Date Issued: September 2017	Page No.: 11	Document No.: SOP-Biosafety-03
Revision: 2.0	Subject: Biological Safety Cabinets	

- **Clean up spills** as soon as they occur. Remove and disinfect the grill if contaminated and remember to clean under the grill.
 - If the spill was relatively large or contained concentrated infectious material then allow the cabinet to sit undisturbed for at least 5 minutes for aerosols to clear before beginning cleanup.
 - While you wait remove and disinfect or dispose contaminated personal protective equipment (PPE) and wash thoroughly.
 - Then don clean PPE and proceed with spill cleanup and decontamination of interior surfaces, including the window/sash.
 - Remember to allow appropriate contact time for the disinfectant.

Upon completion of work:

- Upon completion of work, allow sufficient time for the air in the BSC to purge (i.e., pass through the filter) before disrupting the air curtain by removing hands or unloading material from the BSC. The purge time will vary by model and can be up to several minutes.
- Surface-disinfect objects before removal from the cabinet. Remember that aerosols generated during operations in the cabinet such as pipetting might have contaminated objects in the cabinet, so there does not have to have been a spill for this step to be necessary.
- Disinfect the interior surfaces of the BSC, including sides, back, lights, and interior of the glass, with a disinfectant effective against the pathogens in use, allowing an appropriate contact time (CBS Matrix 4.6). If a corrosive disinfectant is used, the surface should be thoroughly rinsed with water after disinfection to avoid corrosion of the stainless steel surfaces.
- Periodically remove the work surface and disinfect the area beneath it (including the catch pan) and wipe the surface of the UV light with disinfectant.
- If appropriate turn off the blower and fluorescent lamp, and turn on the UV light if appropriate (see section 5.2, Lighting).



Date Issued: September 2017	Page No.: 12	Document No.: SOP-Biosafety-03
Revision: 2.0	Subject: Biological Safety Cabinets	

- Disinfect or dispose of personal protective equipment appropriately and wash hands.

5.4. Warnings:

- Equipment creating air movement (e.g., vacuum pumps, centrifuges) may affect the integrity of the airflow and should not be used within the BSC.
- Windows that open should be kept closed when the BSC is in use.
- Work in a BSC should only be conducted by one person at a time (even in a large BSC).
- **An open flame should not be used in a BSC.** Natural gas and propane should not be used in a BSC; sustained open flames (e.g., Bunsen burner) in BSCs are prohibited. On-demand open flames (e.g., touch-plate microburners) are to be avoided as they create turbulence in the BSC, disrupt airflow patterns, and can damage the HEPA filter (CBS Matrix 4.6). **Non-flame alternatives (e.g., microincinerator, or sterile disposable inoculation loops) should be used whenever possible.**
- The HEPA filters in the BSCs remove particulates from air, but they are **not effective at collecting chemical gases or vapours**. If you need to use such material in a BSC, contact the Biosafety Officer for advice.
- **Routine use of UV lamps to decontaminate a BSC is not recommended** (see section 5.2, Lighting).
- **DO NOT use the BSC if the ALARM sounds or if there are other indications of cabinet malfunction such as no airflow, reduced pressure on magnehelic gauge (drop > 0.2), or unusual noises.**

If alarm or other indication of failure happens while using the cabinet:

- Seal, surface decontaminate and remove any biohazardous material.
- Decontaminate the interior of the BSC.
- Switch off the alarm or the power if the motor is making noise.
- Place a sign on the cabinet to indicate that it is broken and must not be used.
- Contact Environmental Health and Safety for advice and servicing (ext. 32999).



Date Issued: September 2017	Page No.: 13	Document No.: SOP-Biosafety-03
Revision: 2.0	Subject: Biological Safety Cabinets	

- **If personnel may have been exposed to infectious material due to cabinet failure, then the supervisor must be promptly notified and an incident report completed and the appropriate first aid and medical follow-up action taken.**
- To help protect the fragile air curtain at the front of the cabinet, BSCs must be located as far as possible away from areas where airflow patterns may be disrupted e.g., room air supply and exhaust grilles, doors, open windows, high traffic areas, and large pieces of equipment that generate heat (CBS Matrix 3.7.6).
 - Consult EH&S if your BSC appears to be located in an area where the air curtain may be disrupted. EH&S can do a smoke test on the air curtain, and propose remedial actions.

6. Maintenance/Certification of Biological Safety Cabinets

When used for biosafety level 2 containment, biological safety cabinet performance must be tested and certified (as specified in CBS Matrix 5.1):

- upon initial installation in the laboratory
- annually thereafter
- when moved from one area to another within the same room, or from one room to another
- whenever maintenance is carried out on internal parts, and whenever filters are changed

In biosafety level 1 laboratories biological safety cabinets are often used primarily for product protection rather than personnel protection. Therefore for biosafety level 1 containment laboratories the testing and certification of biological safety cabinets noted above is recommended but not required.

To arrange BSC maintenance or testing and certification please email tom.martinek@queensu.ca

7. **Information and Enquires:** for technical questions or maintenance issues contact the BSC technician (ext. 74976); for other questions contact the University Biosafety Officer (ext. 77077).
8. **Approval and Revision History:** approved by the University Biohazards Committee

1.0 September 2009: Initial Release

2.0 September 2017: Update to include information from CBS 2nd Edition 2015 and CBH 1st Edition, 2016

Appendix I - Queen's University SOP-Biosafety-03 Biological Safety Cabinets

Table and Figures showing different types of BSC, copied from the Canadian Biosafety Handbook, 1st Edition, 2016, Chapter 11

Table 11-1: Summary Table of Key Characteristics of Class II Biological Safety Cabinets (BSCs)

	Type A1	Type A2	Type B1	Type B2
Minimum average inflow velocity through front opening	0.38 m/s [75 fpm]	0.51 m/s [100 fpm]	0.51 m/s [100 fpm]	0.51 m/s [100 fpm]
Air patterns	30% of the air is exhausted out of the BSC and 70% of the air is recirculated within the BSC	30% of the air is exhausted out of the BSC and 70% of the air is recirculated within the BSC	>50% of the air is exhausted out of the BSC and <50% of the air is recirculated within the BSC	100% of the air is exhausted out of the BSC
HEPA-filtered downflow air	Composed of mixed downflow and inflow from common plenum	Composed of mixed downflow and inflow from common plenum	Inflow air	Drawn from the containment zone or from the outside atmosphere
HEPA-filtered exhaust air	Recirculated to the containment zone or directly to the outside atmosphere	Recirculated to the containment zone or directly to the outside atmosphere	Exhausted through dedicated exhaust plenum to the outside atmosphere	Exhausted through dedicated exhaust plenum to the outside atmosphere
Type of exhaust	Can be thimble connected	Can be thimble connected	Hard-ducted	Hard-ducted
Contaminated ducts and plenums	Negatively pressured or surrounded by negatively pressured ducts or plenums; plenum may be positively pressured in some models	Negatively pressured or surrounded by negatively pressured ducts or plenums	Negatively pressured or surrounded by negatively pressured ducts or plenums	Negatively pressured or surrounded by negatively pressured ducts or plenums
Work with volatile toxic chemicals and radionuclides	No	Minute amounts if exhausted through thimble connection	Low levels of volatile toxic chemicals and trace amounts of radionuclides	Yes

Figure 11-2: Illustration of a Class II Type A1 Biological Safety Cabinet (BSC) (with a Positively Pressured Contaminated Plenum)

Cabinet exhaust may be recirculated into the room or vented to the outside atmosphere through an air gap type (thimble) connection, as shown. Purple shading indicates positively pressured contaminated plenum.

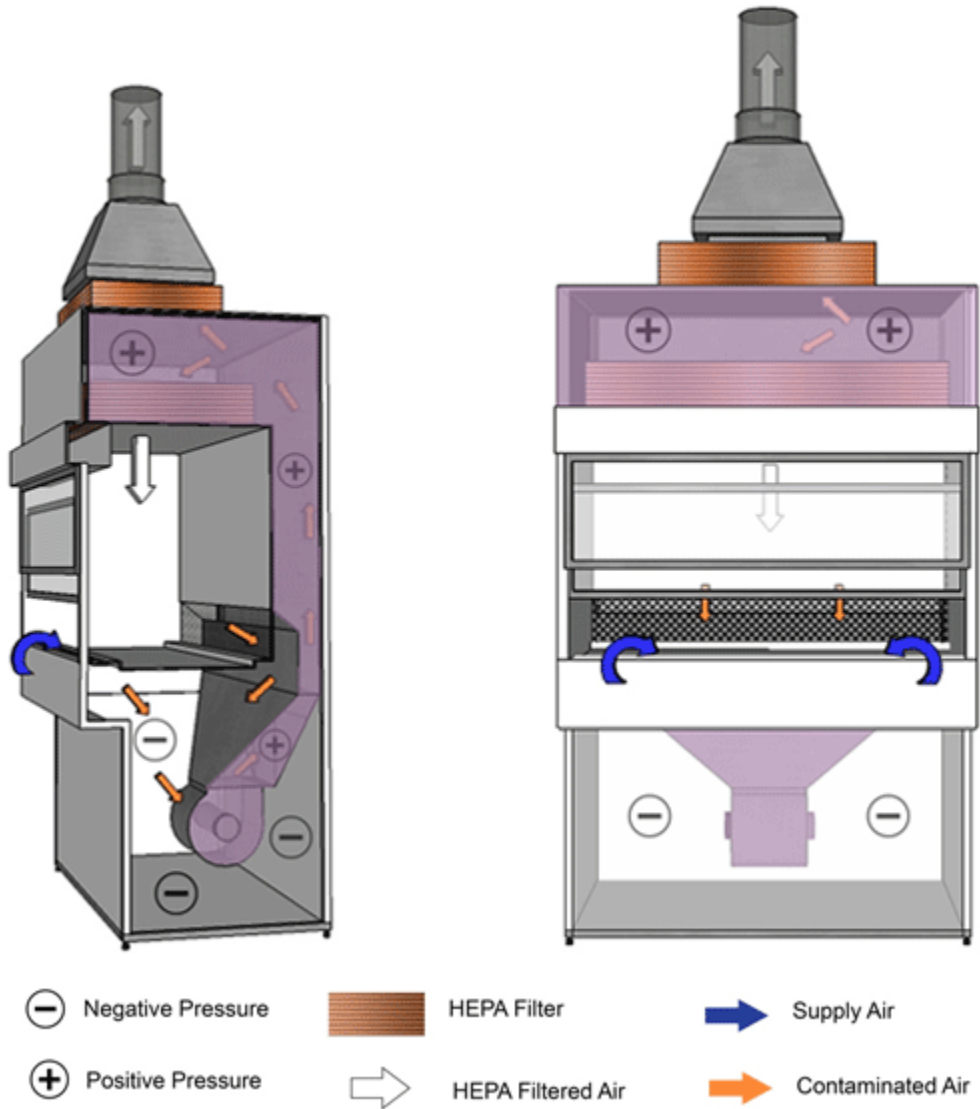

Figure 11-3: Illustration of a Class II Type A2 Biological Safety Cabinet (BSC)

Cabinet exhaust may be recirculated into the room or vented to the outside atmosphere through an air gap type (thimble) connection, as shown. Cabinet shown has a negatively pressured plenum.

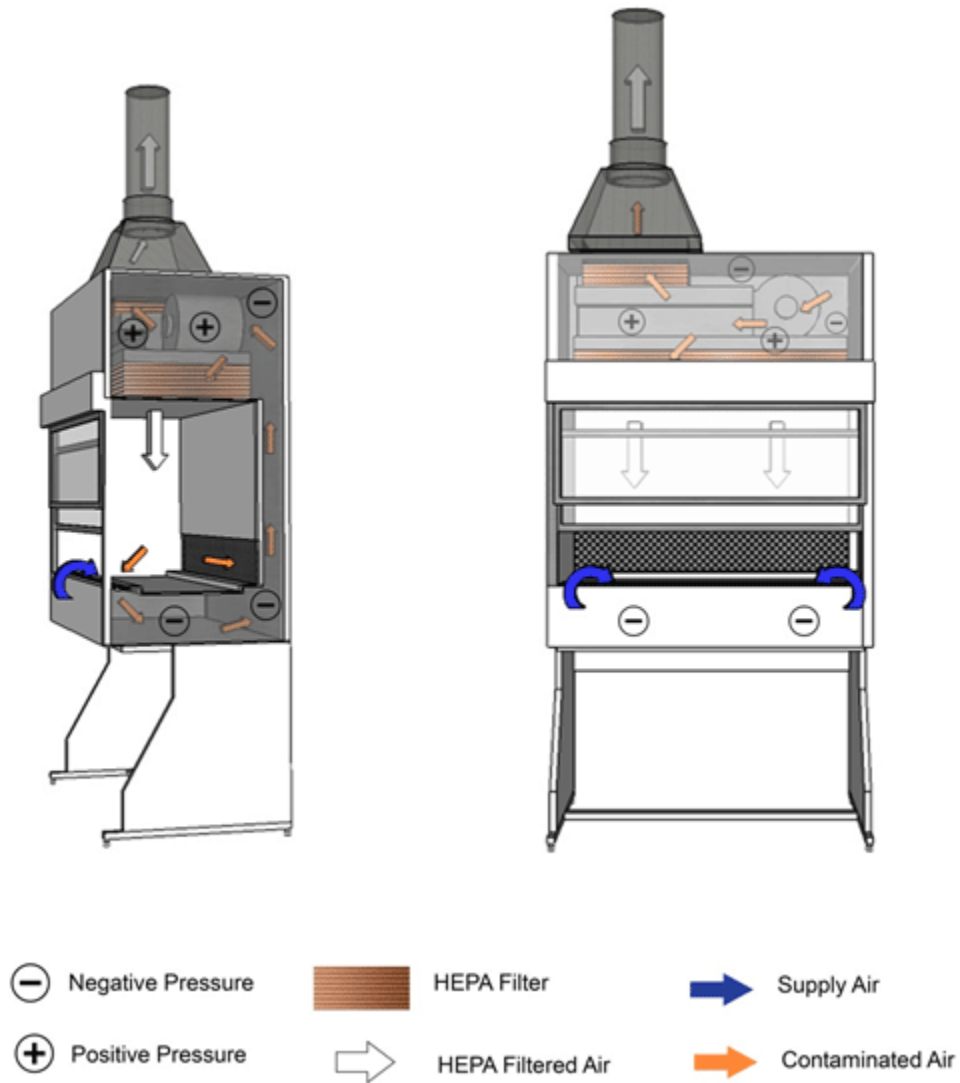

Figure 11-5: Illustration of a Class II Type B2 Biological Safety Cabinet (BSC)

Cabinet is vented to the outside atmosphere through a hard-ducted connection, as shown.

